

Part No.

# NPAK-0001

*NPAK Tank valve block, aluminum*

Replacement parts for hand pumps, calibration manifolds, nitrogen sources and volume controllers

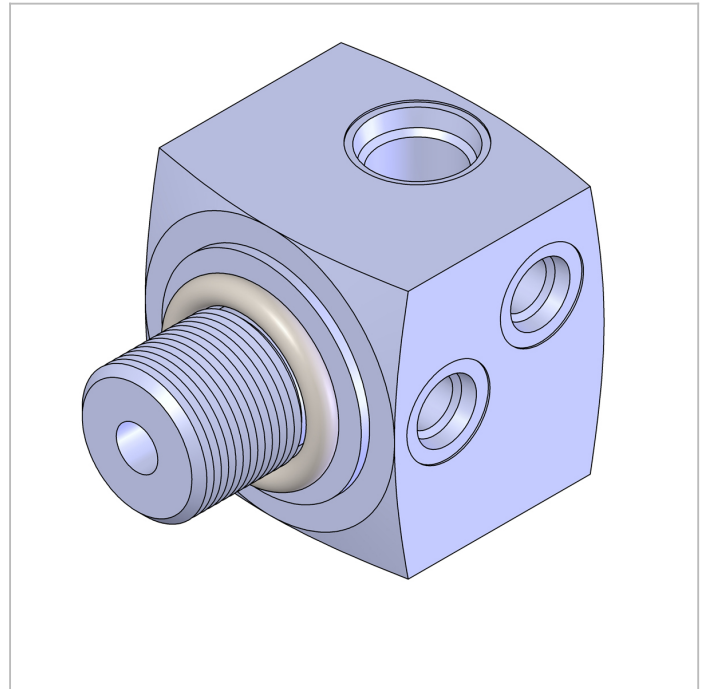

NPAK-0001

## Specs/Attributes

Max Pressure	0.00 PSI / 0.00 mbar / 0.00 kPa
Max Vacuum	0.00 InHg / 0.0 kPa
Country of origin	USA
Weight	5.22 oz / 150 grams
Dimensions	H: 2.07 in (5.26 cm) x W: 1.51 in (3.84 cm) x D: 1.51 in (3.84 cm)